

MOUNTAIN TOP[®] **BRACING KIT**

Installation manual

Parts

A		x1	B		x1
LEFT			RIGHT		
C		x1	D		x1
LEFT			RIGHT		

Kit

E		x4	F		x4	G		x6
H		x4	I		x16	J		x4
K		x6	L		x1	M		x4
				Warning sticker			Label	
			N		x1			
				INSTALLATION MANUAL				

Tools and materials needed

1 - 25 Nm

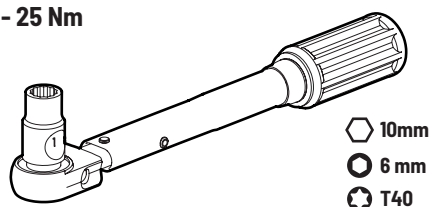

Ford Wildtrak
Model Year <2019

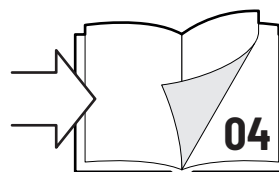

Ford Wildtrak
Model Year 2019

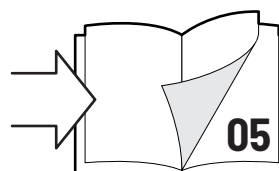

Ford Wildtrak
Model Year >2020

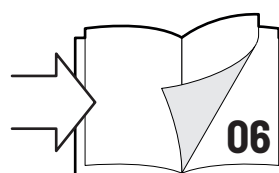

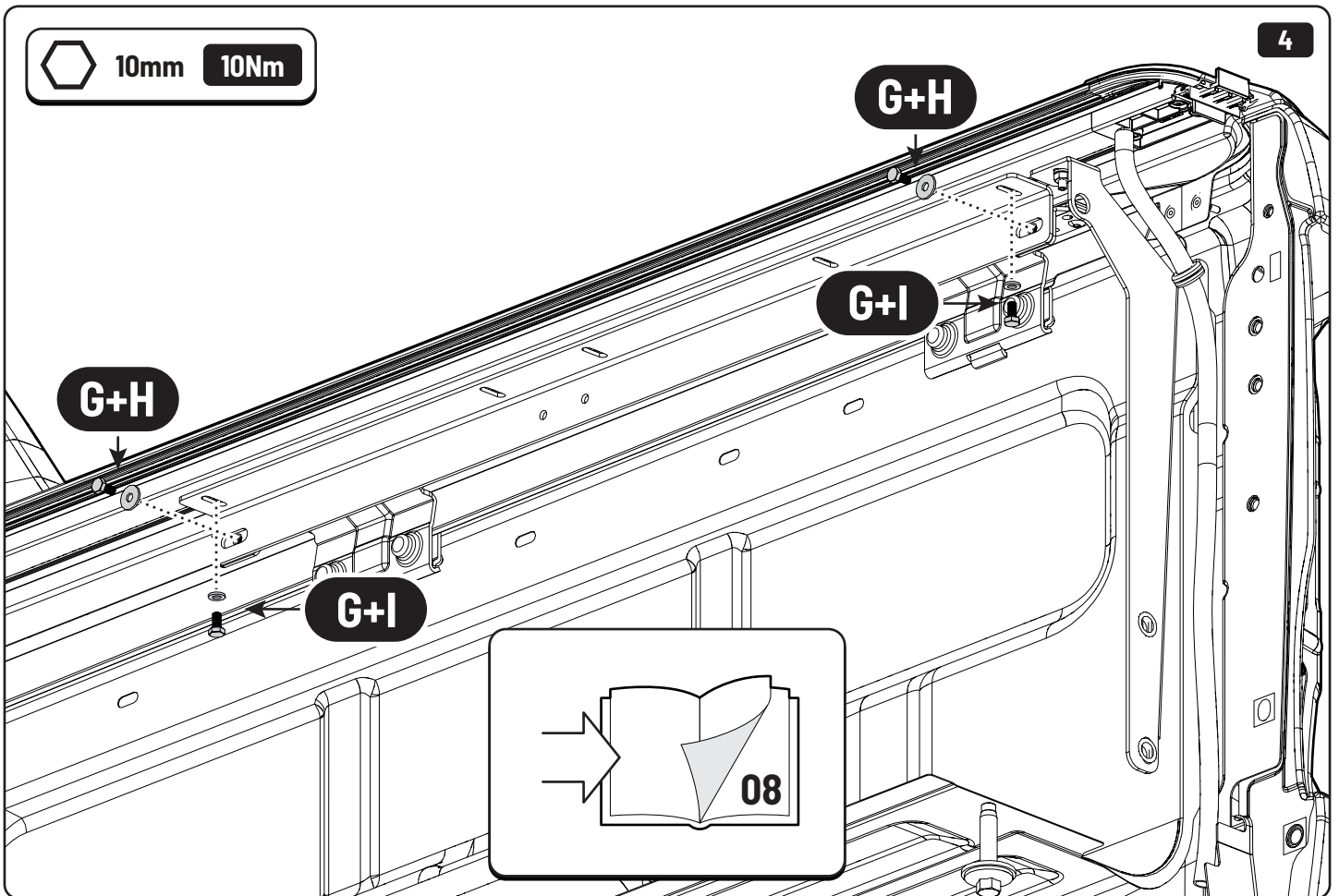
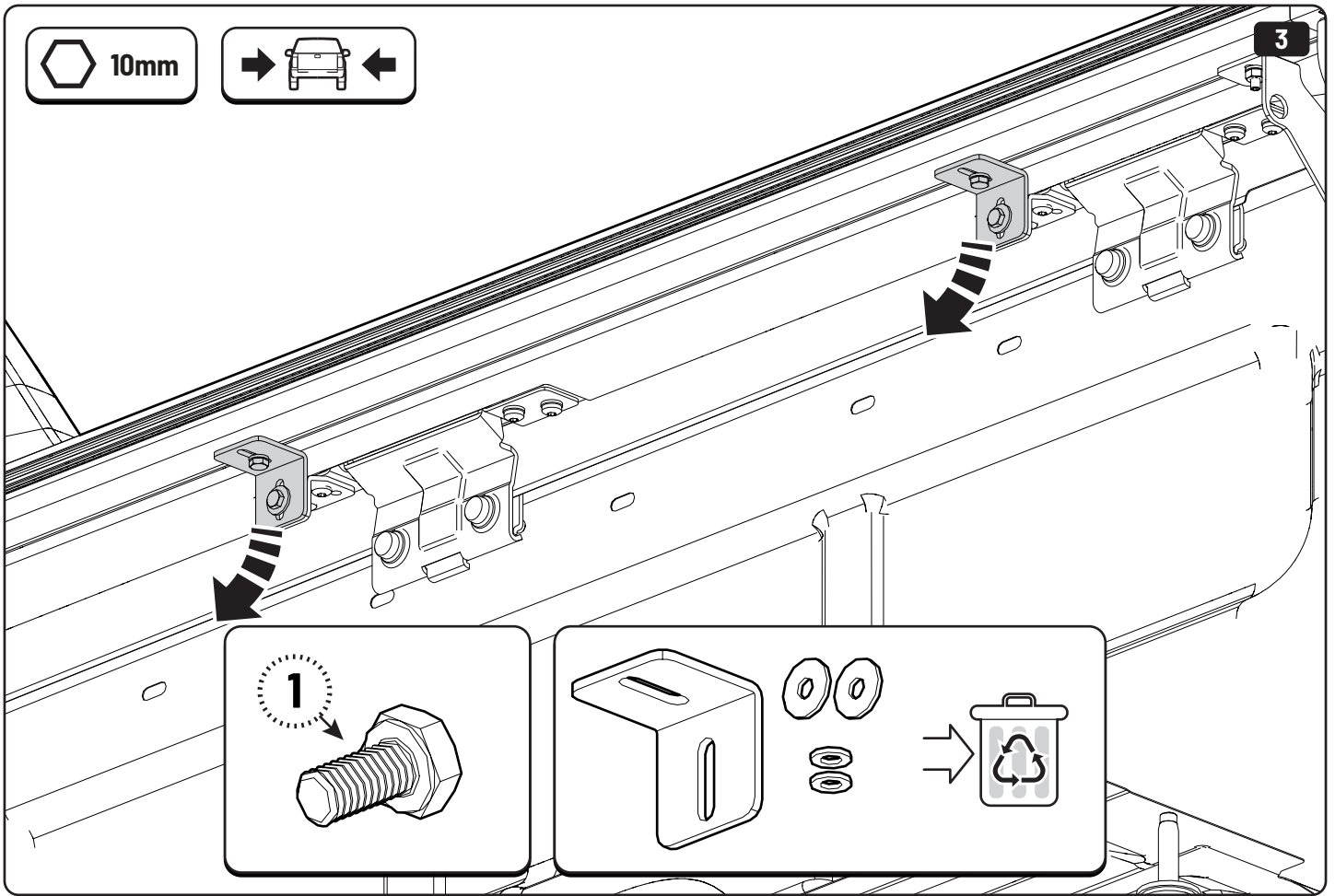

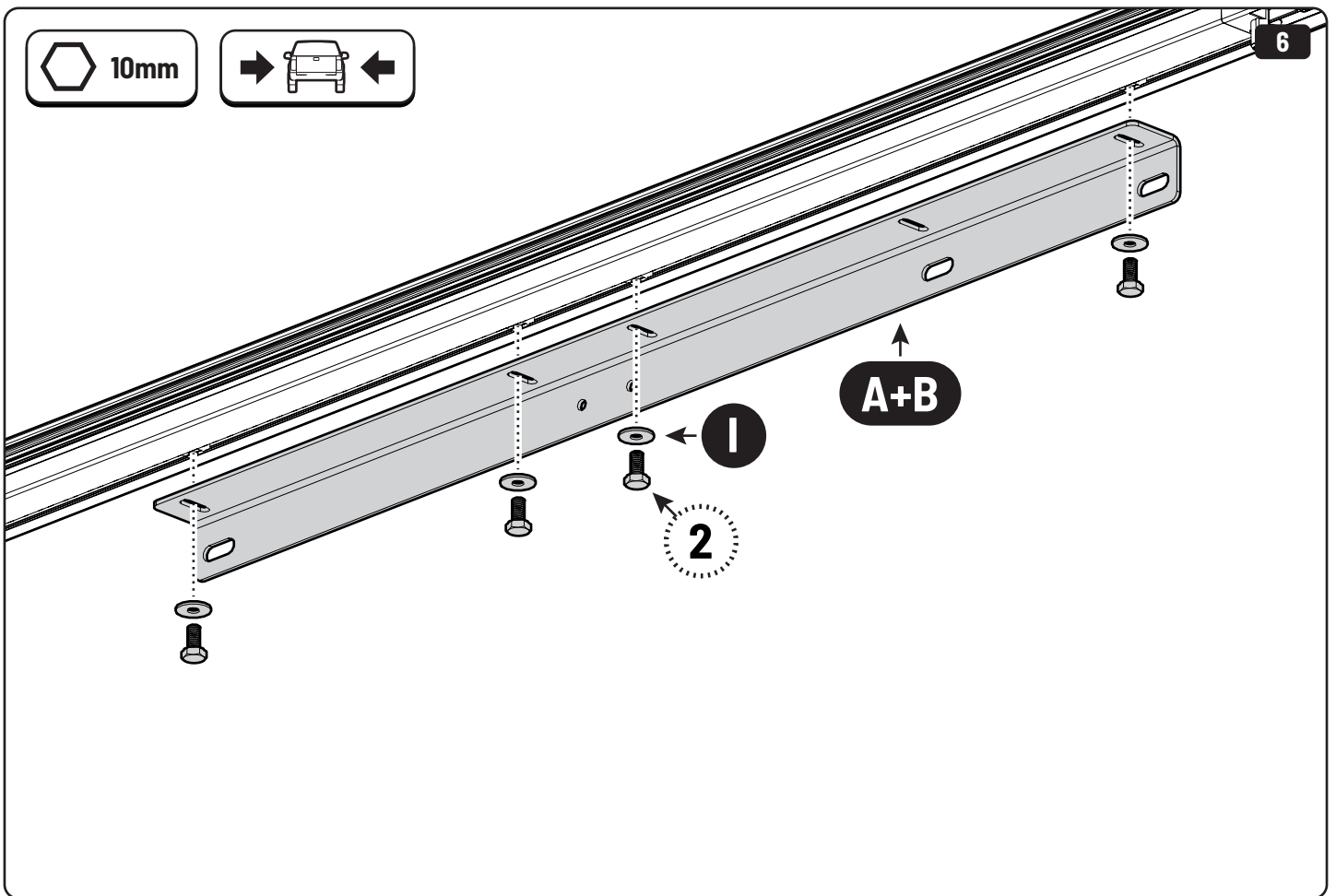
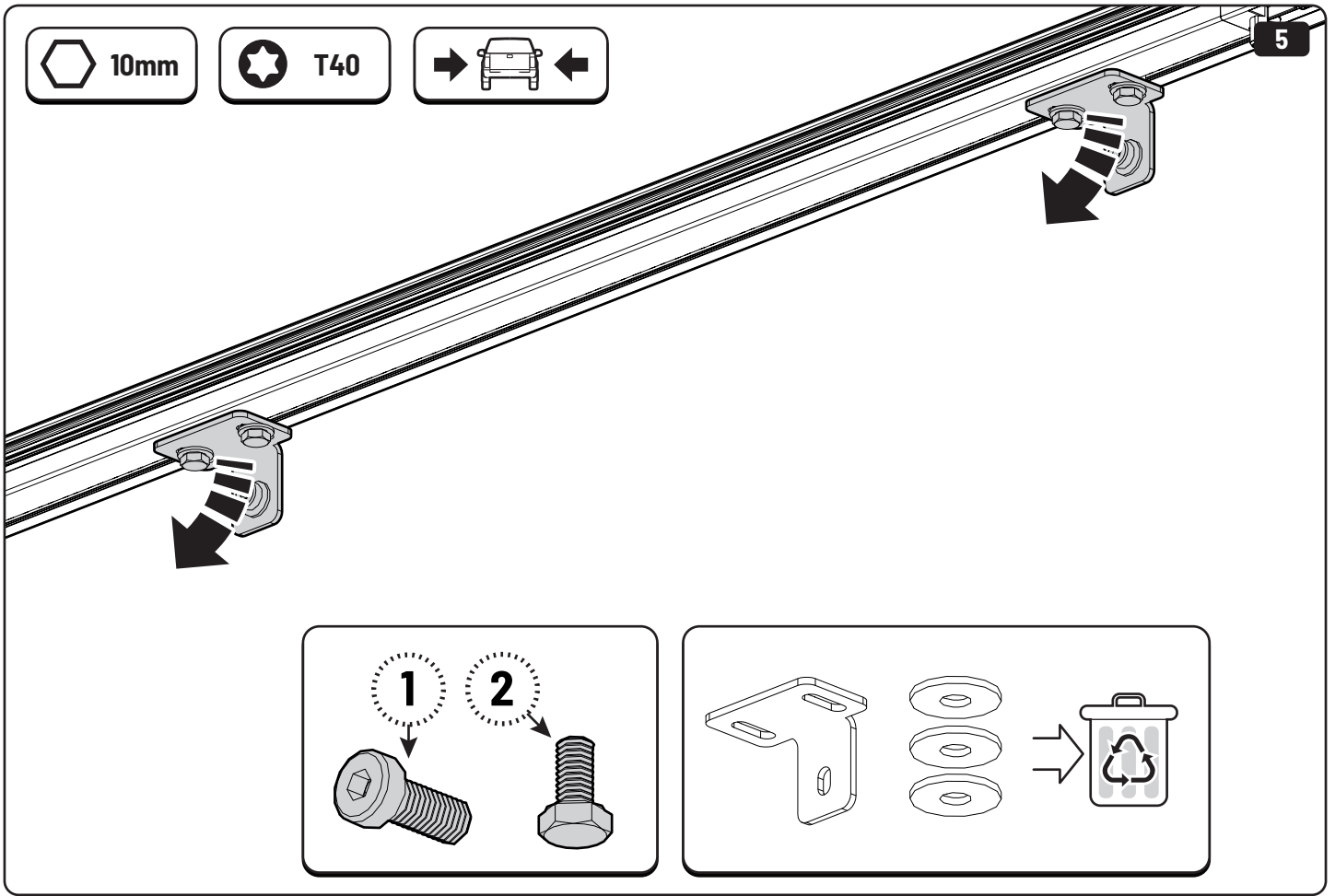

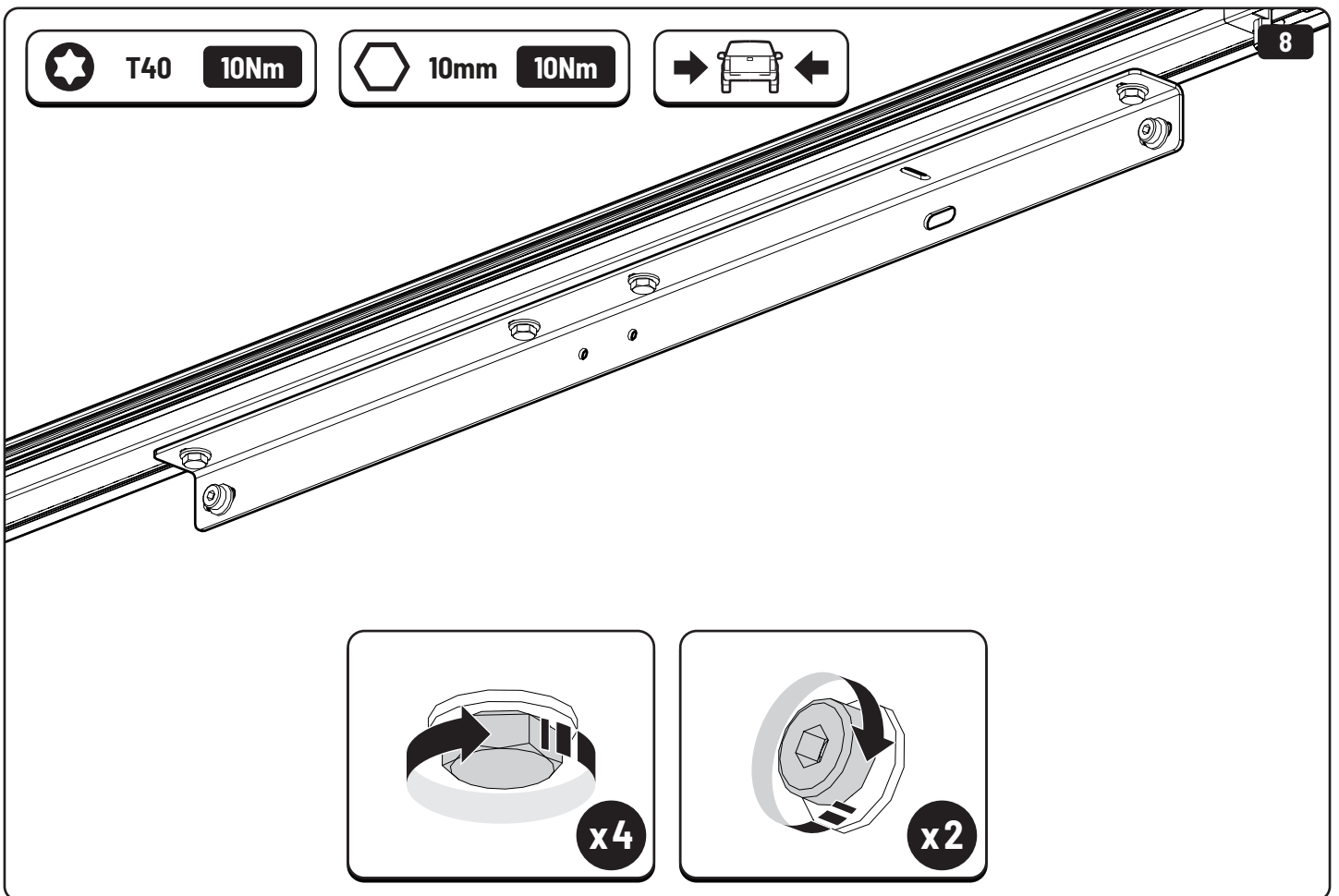
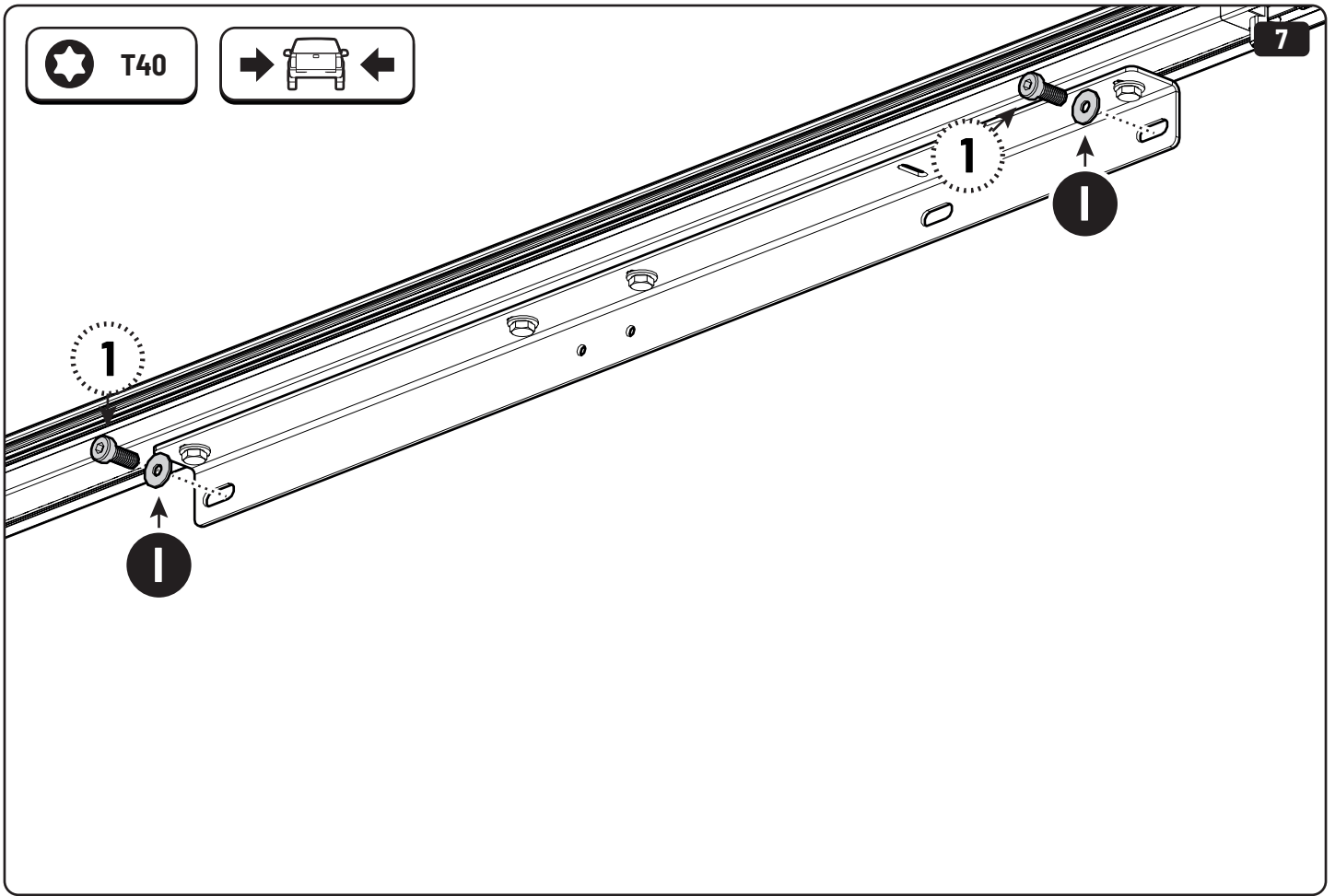

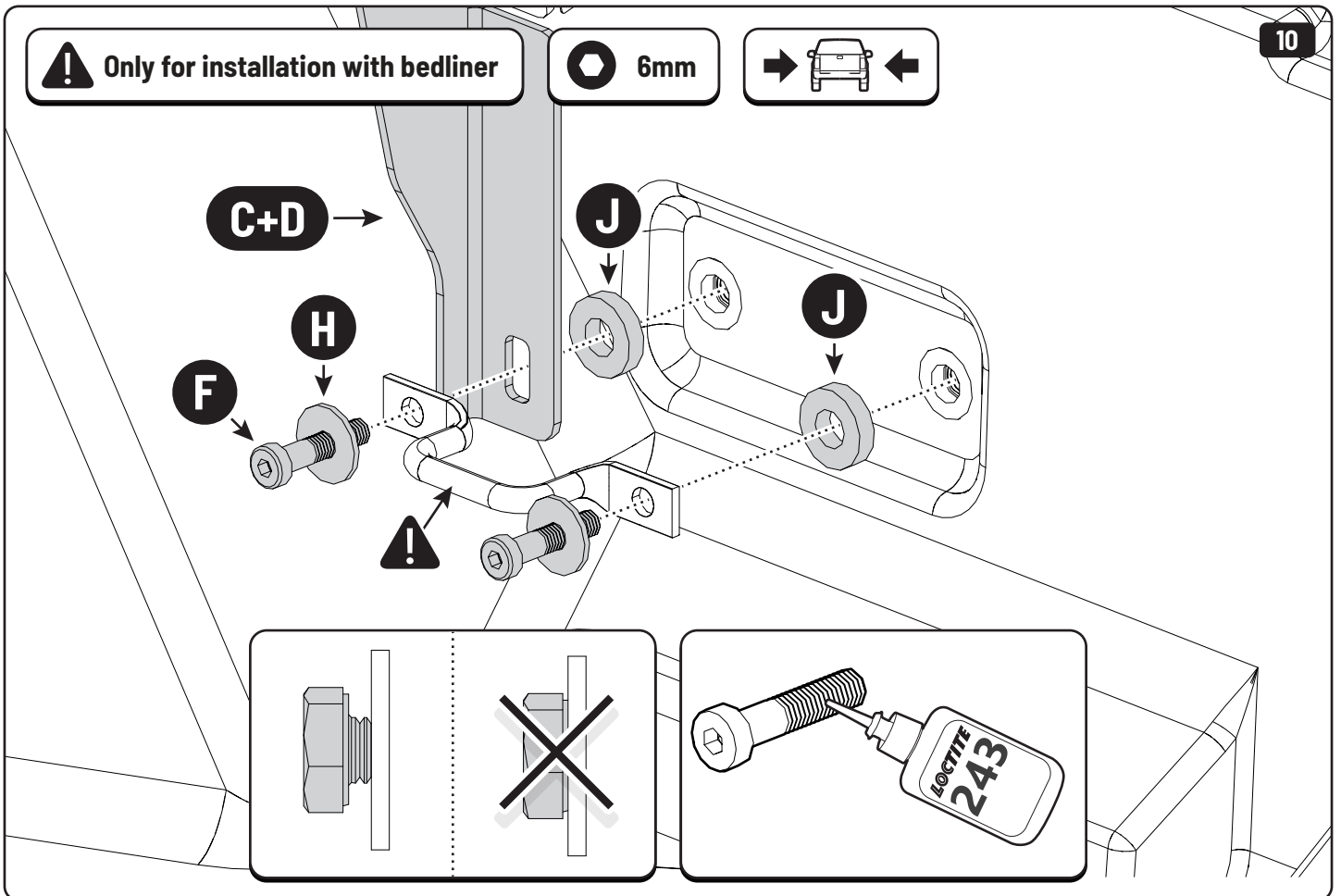
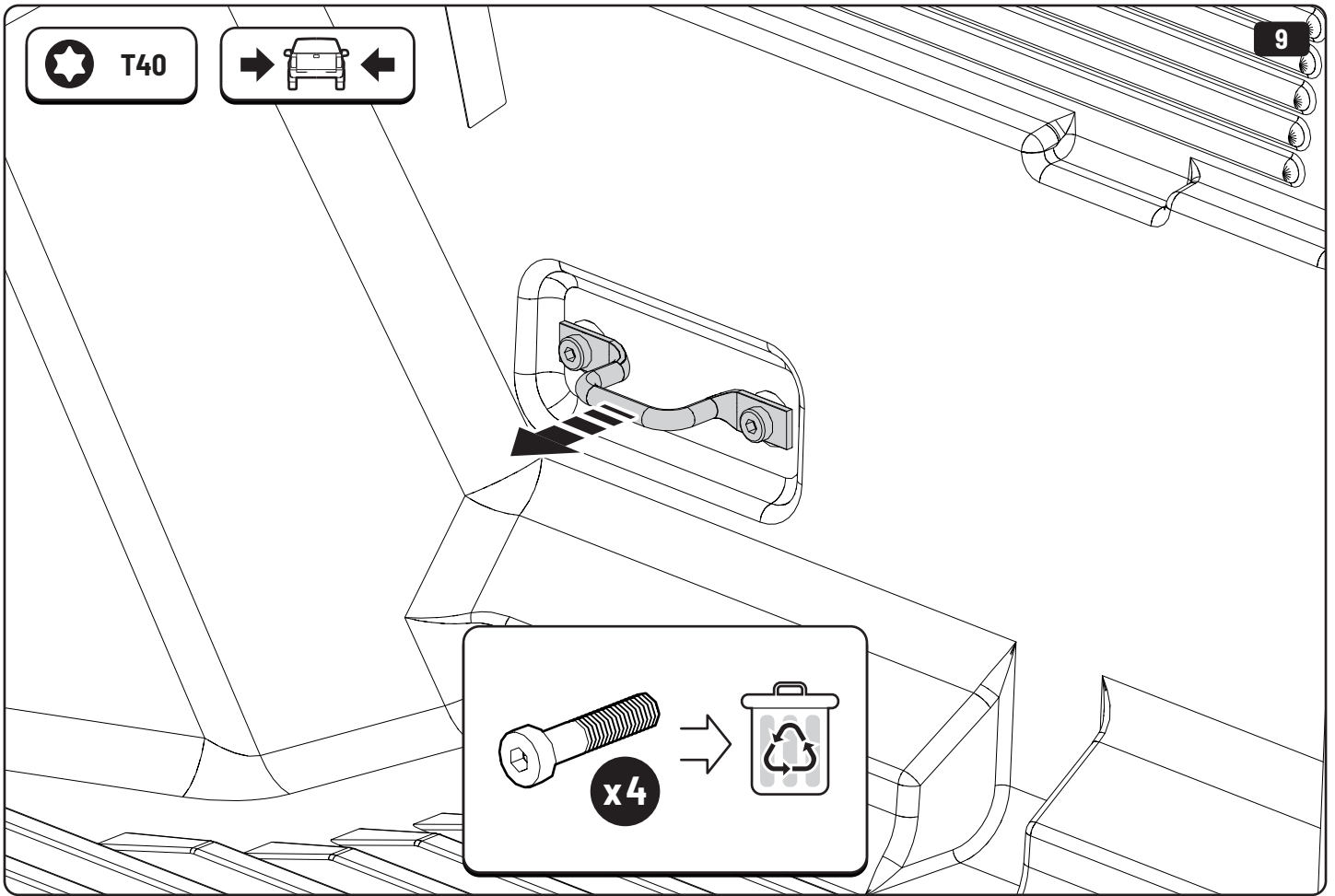

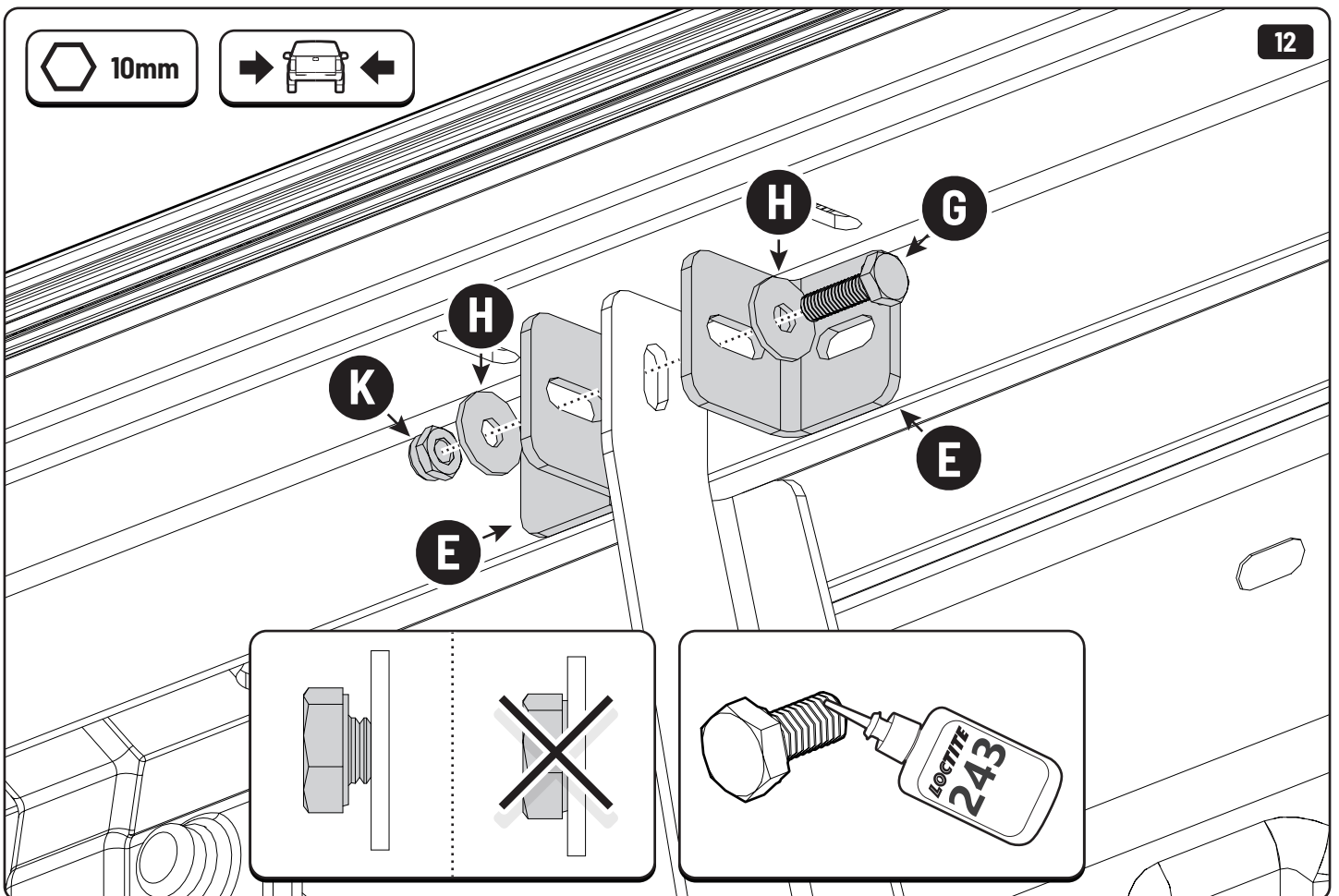
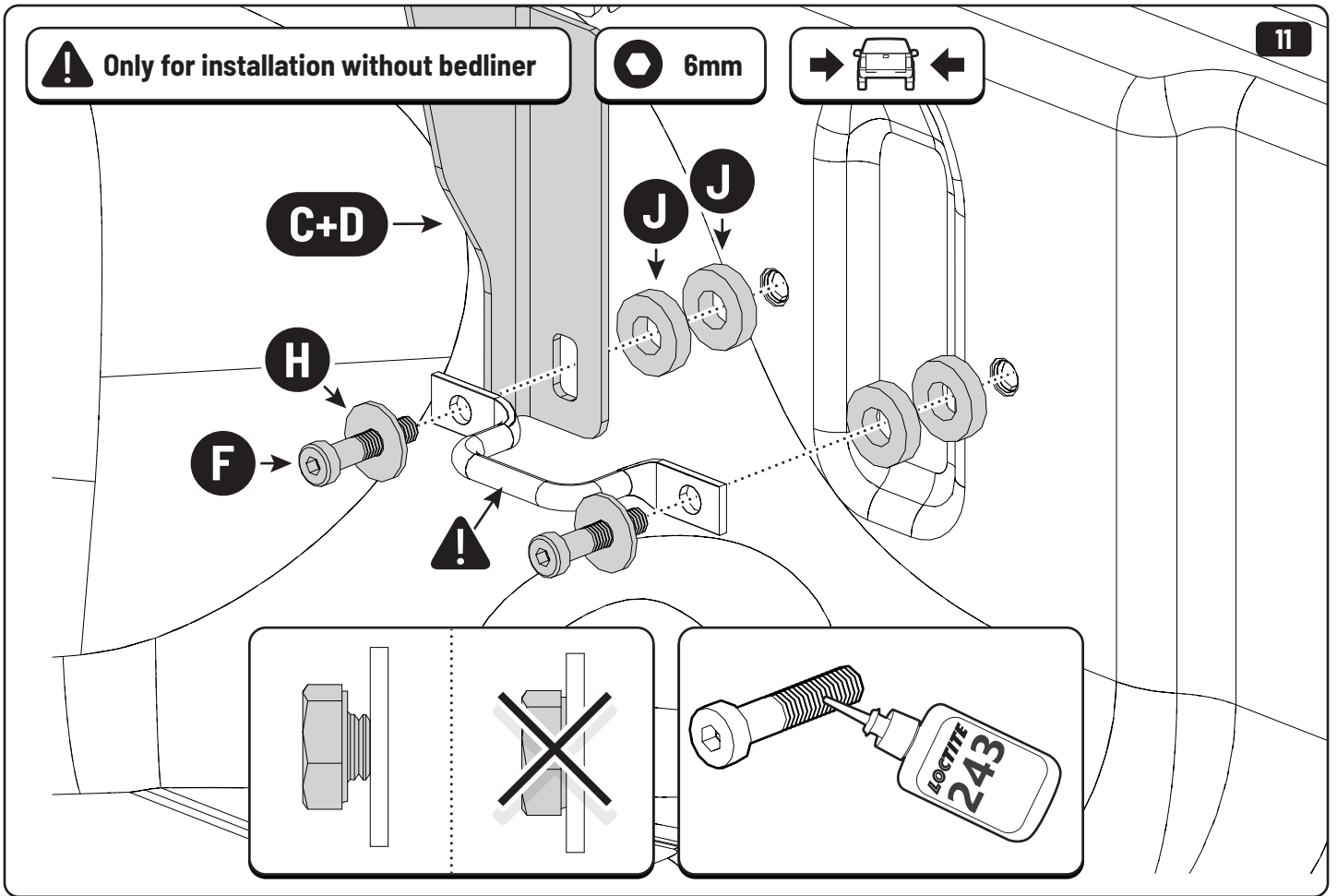

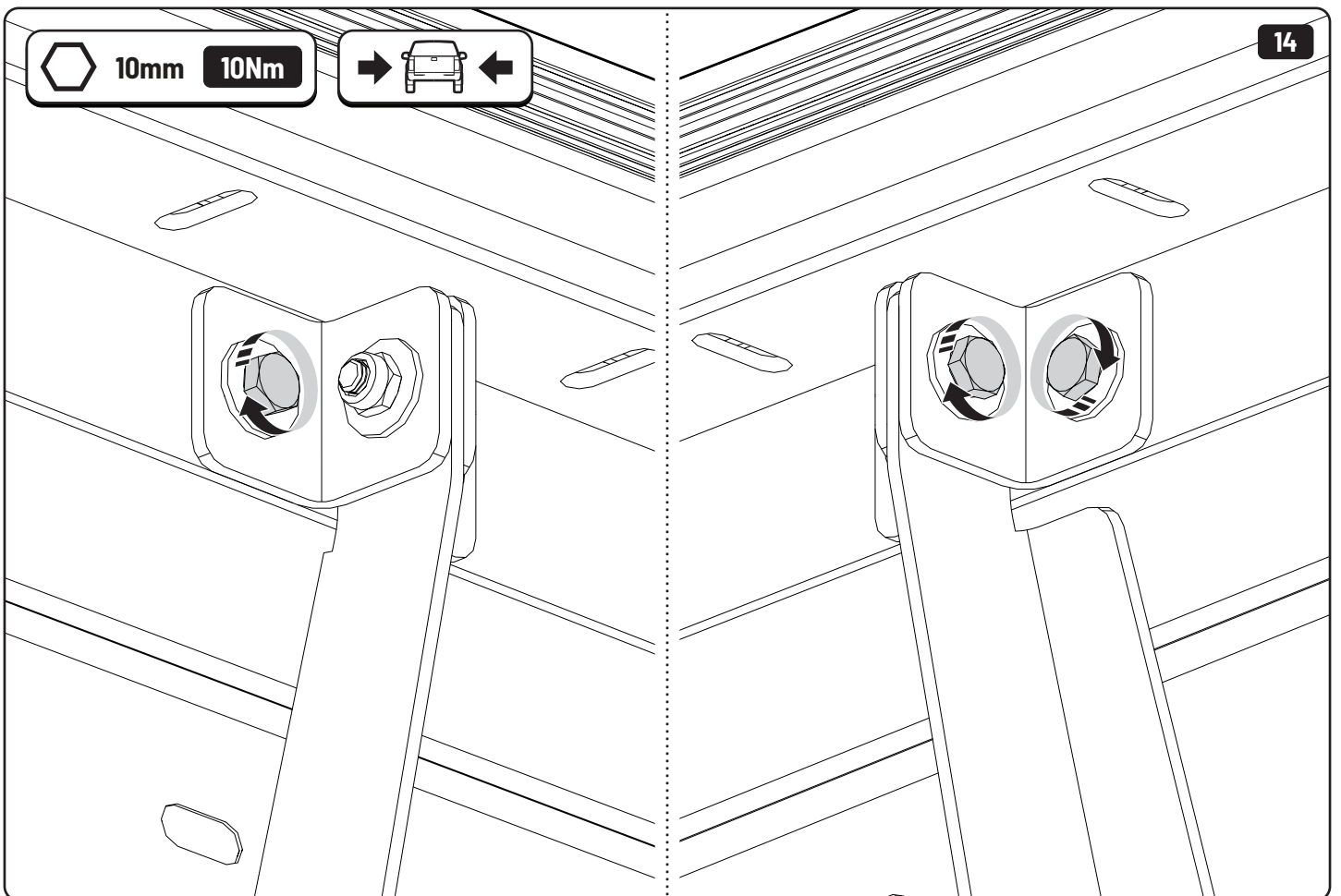
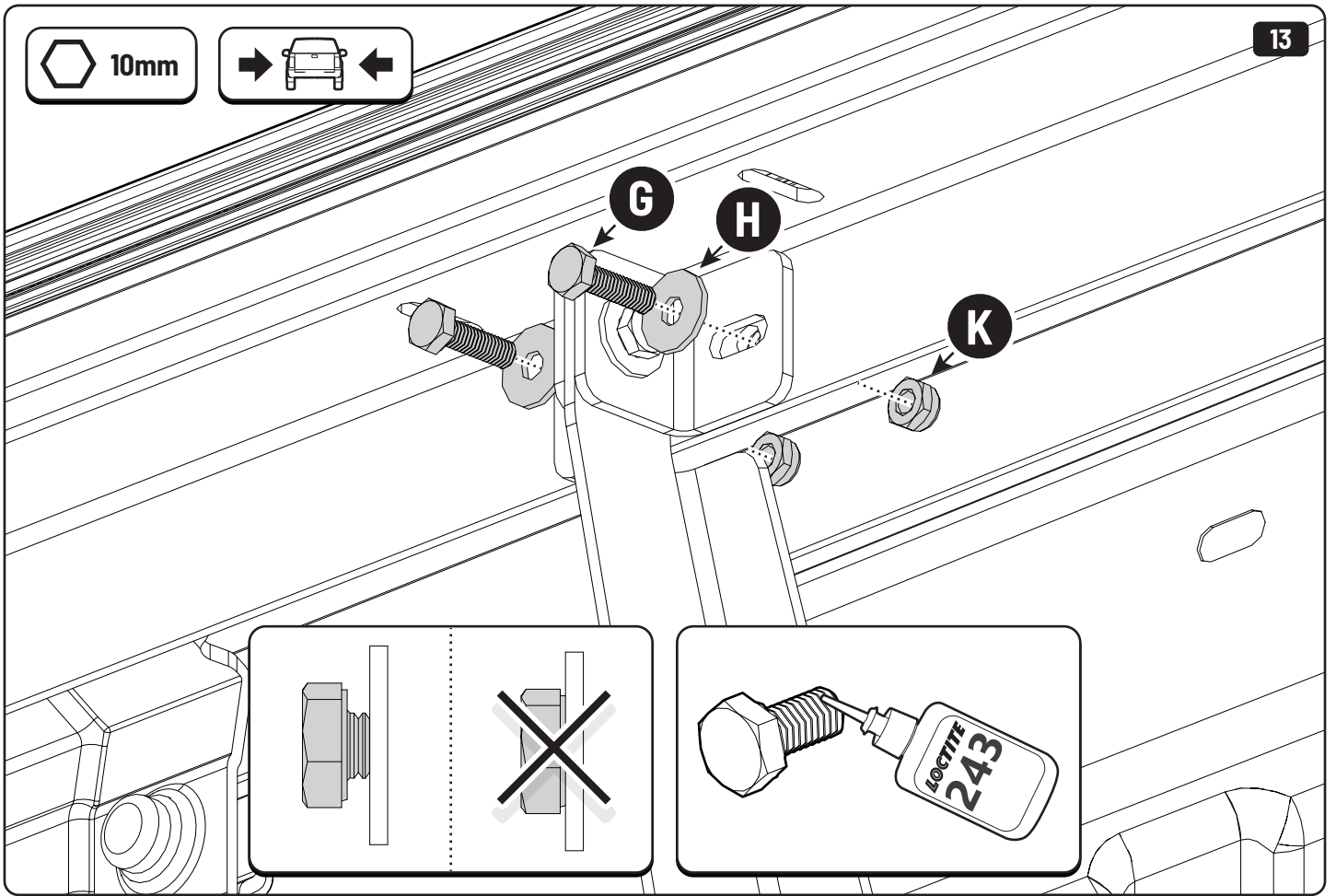

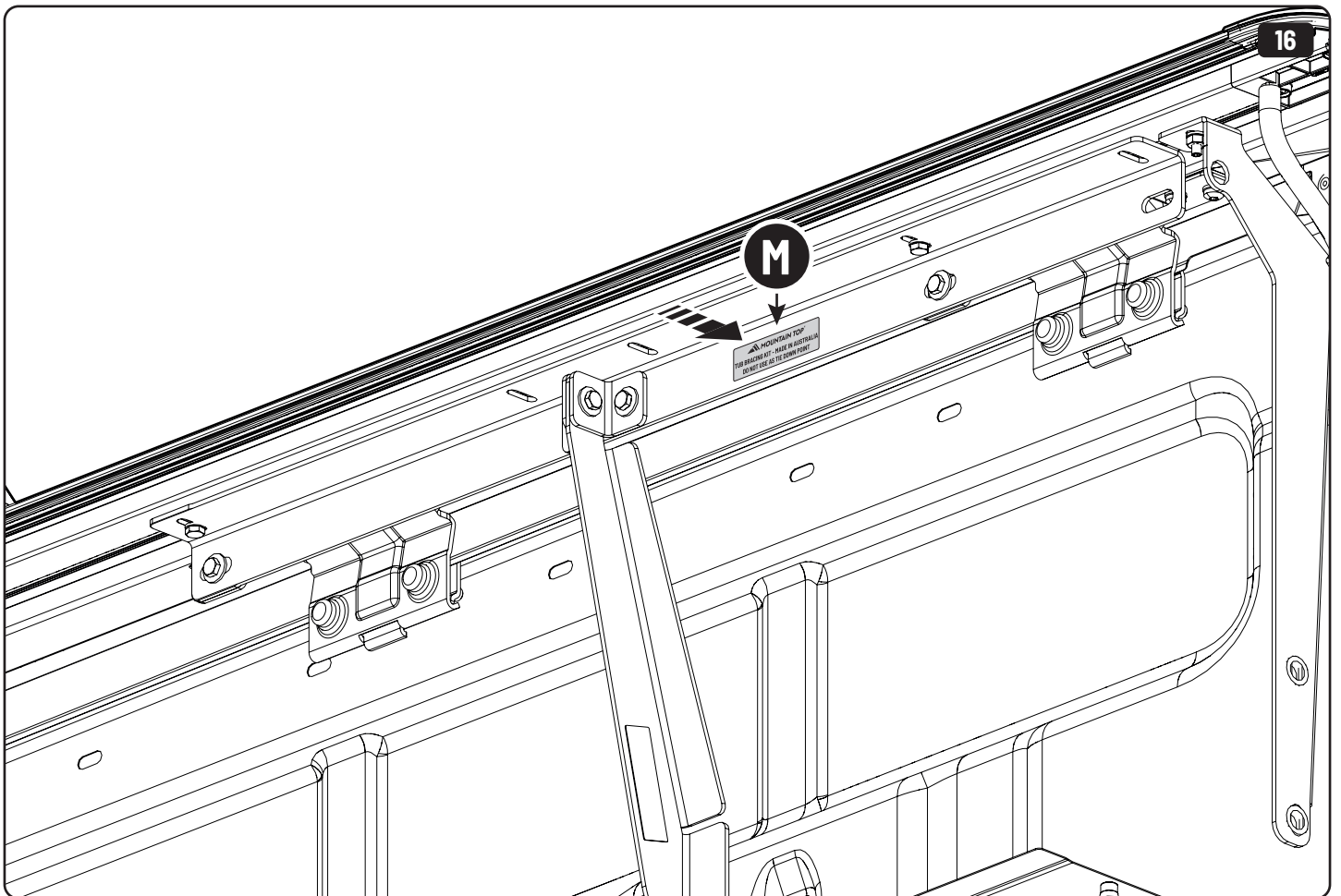
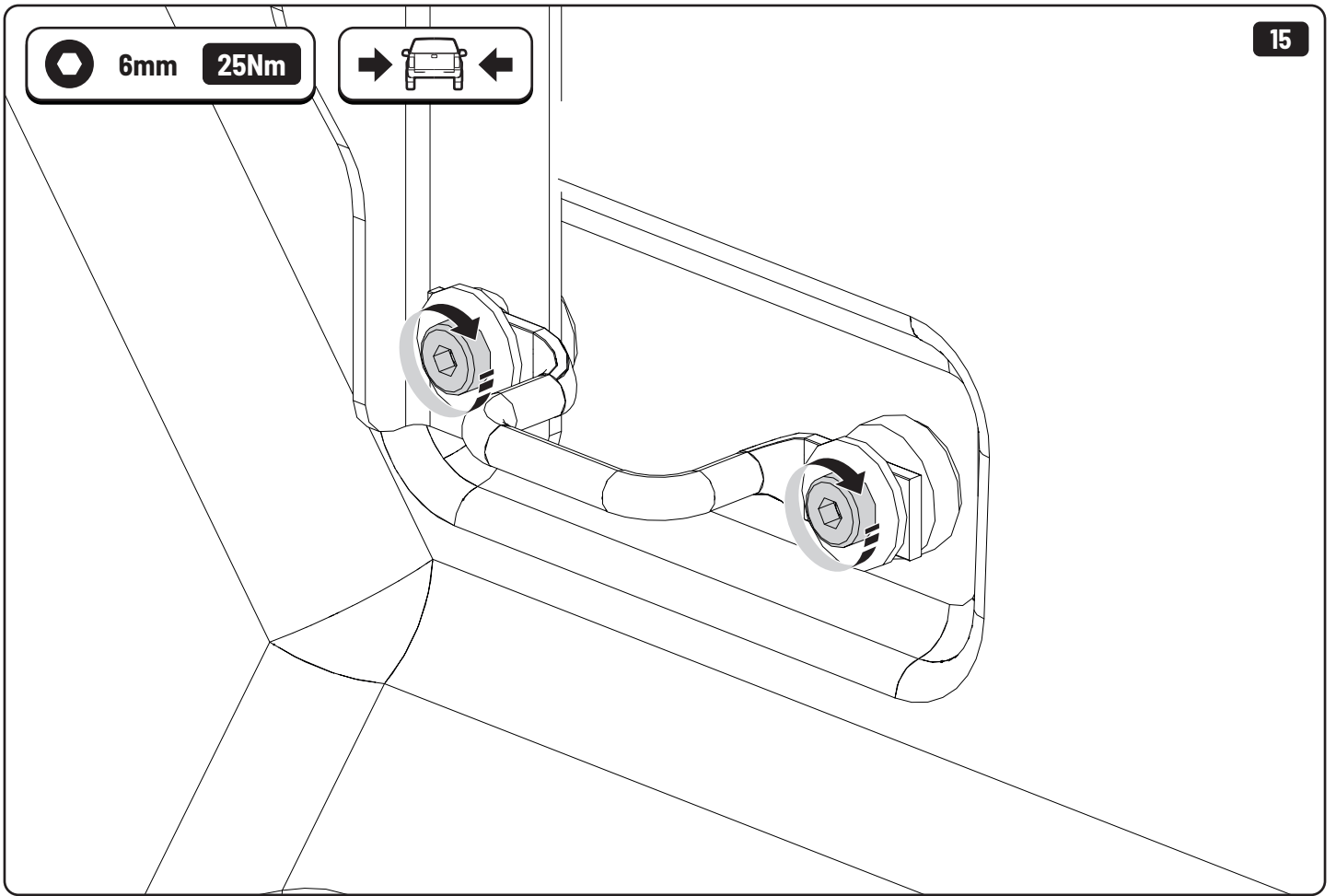

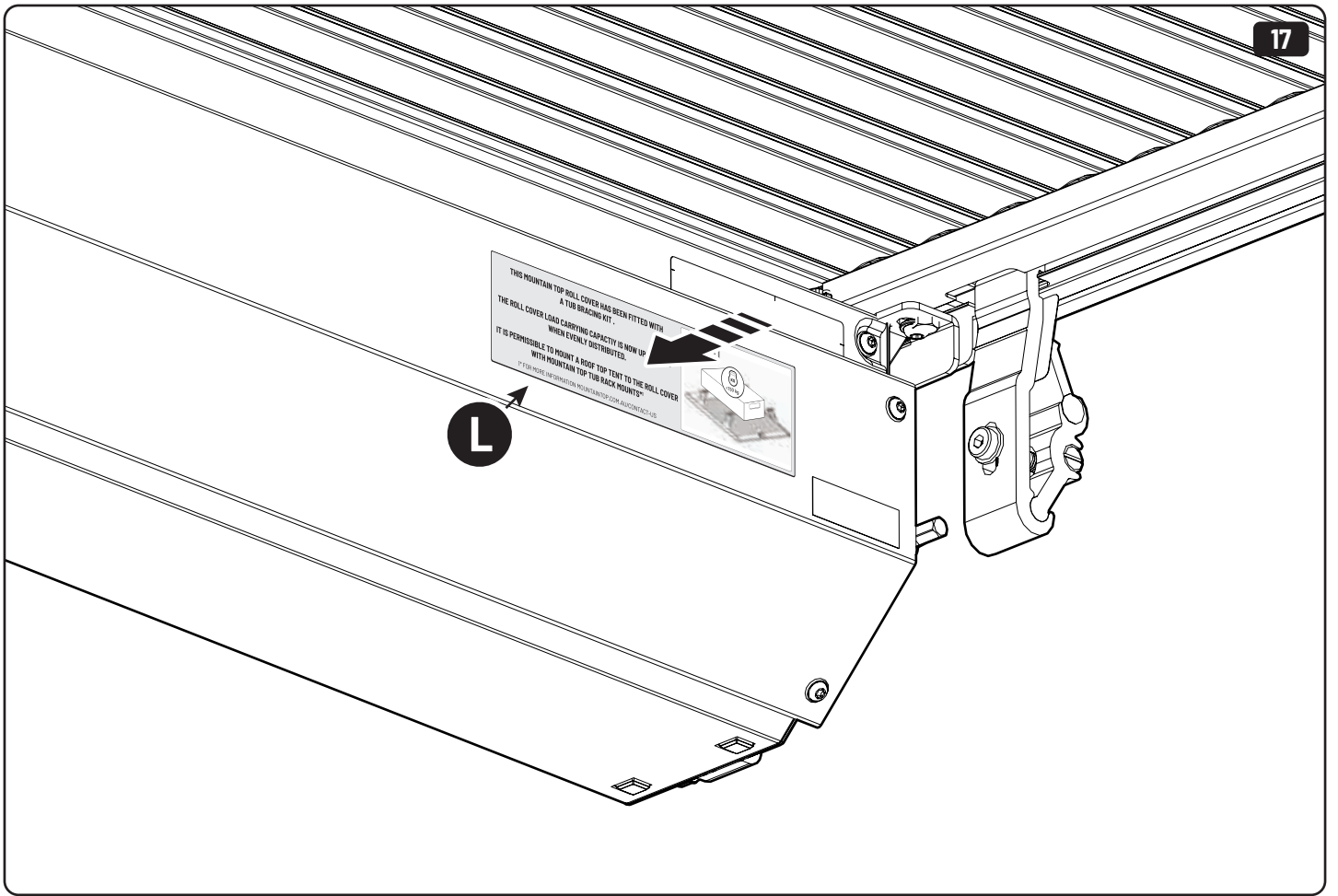

☰ ✓ **Check function**

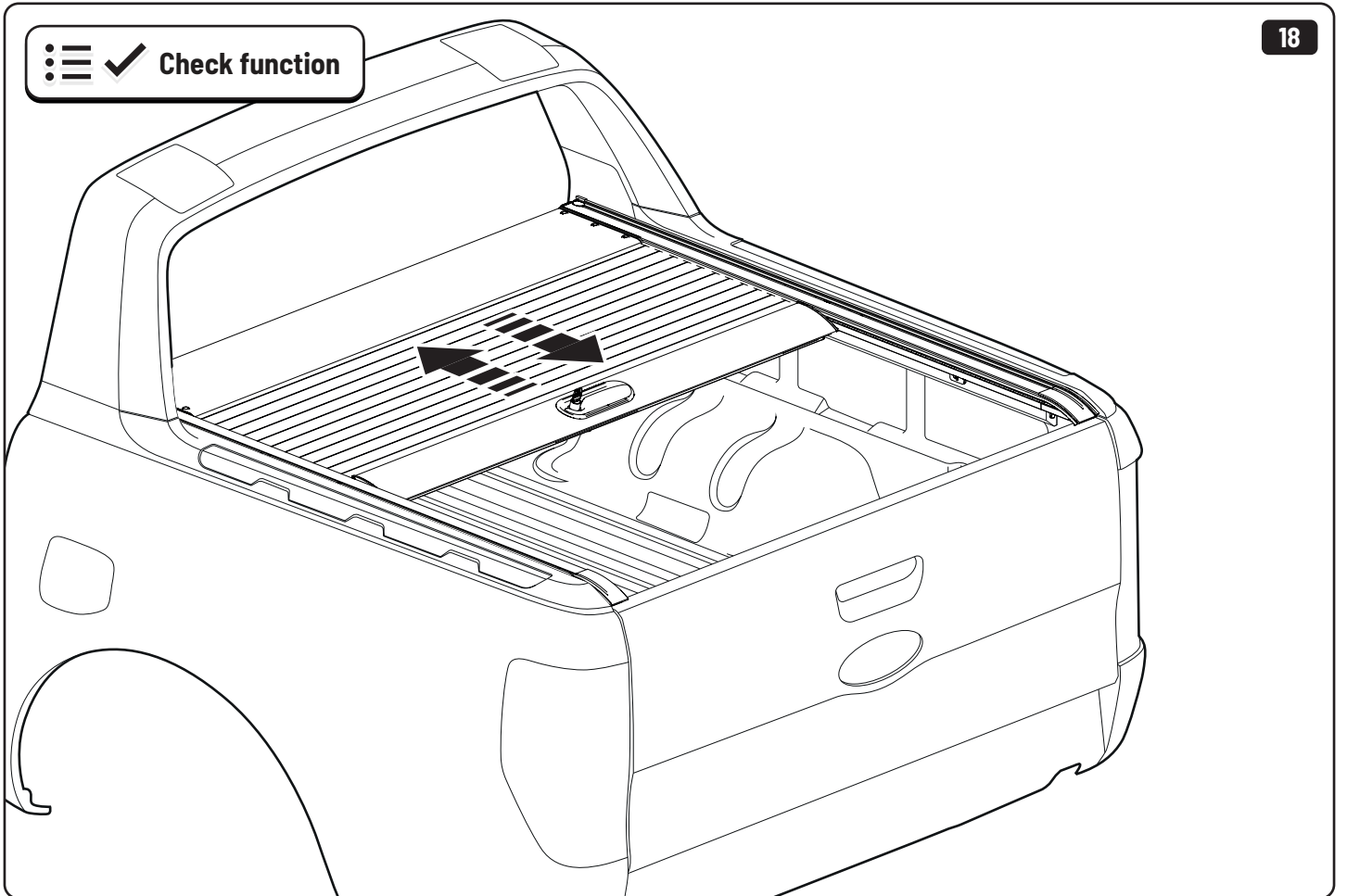

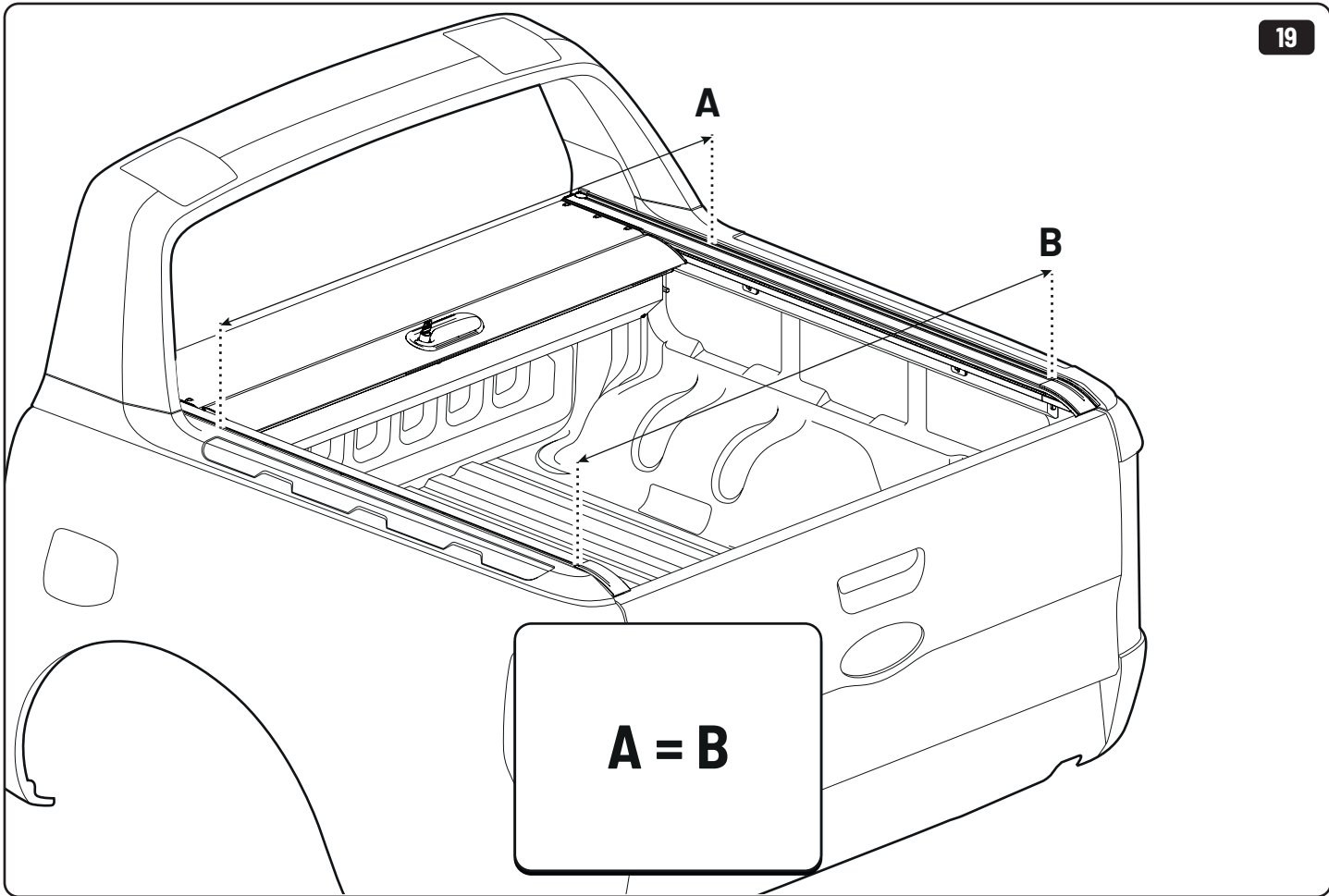

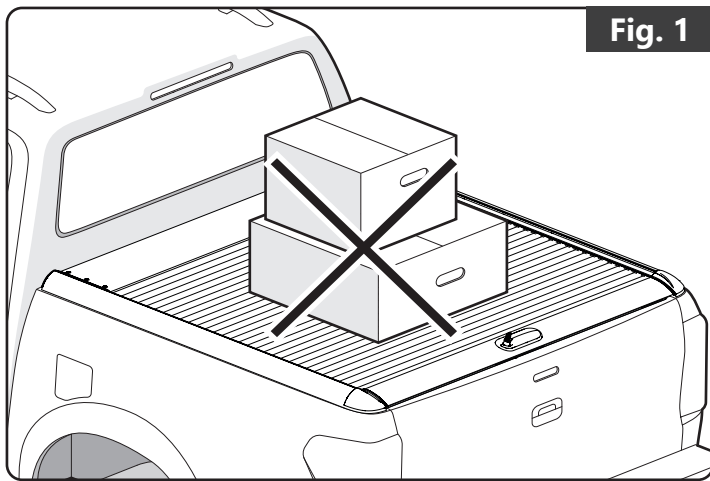

Fig. 1

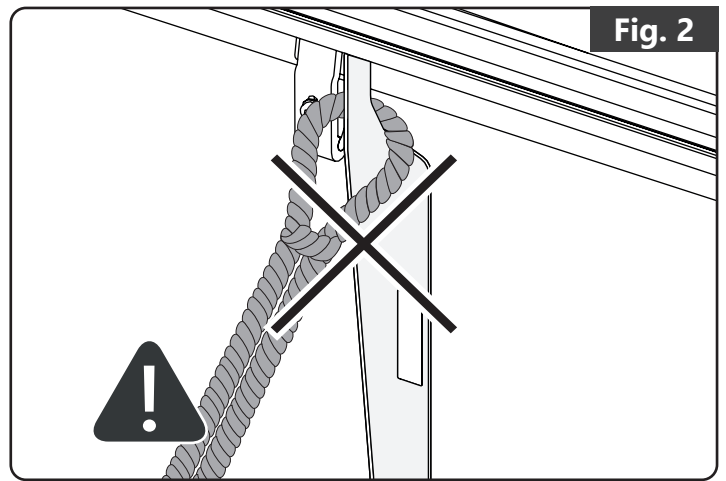
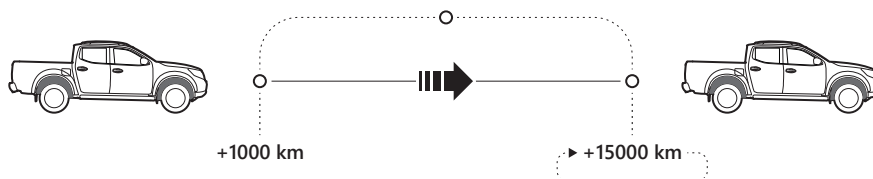
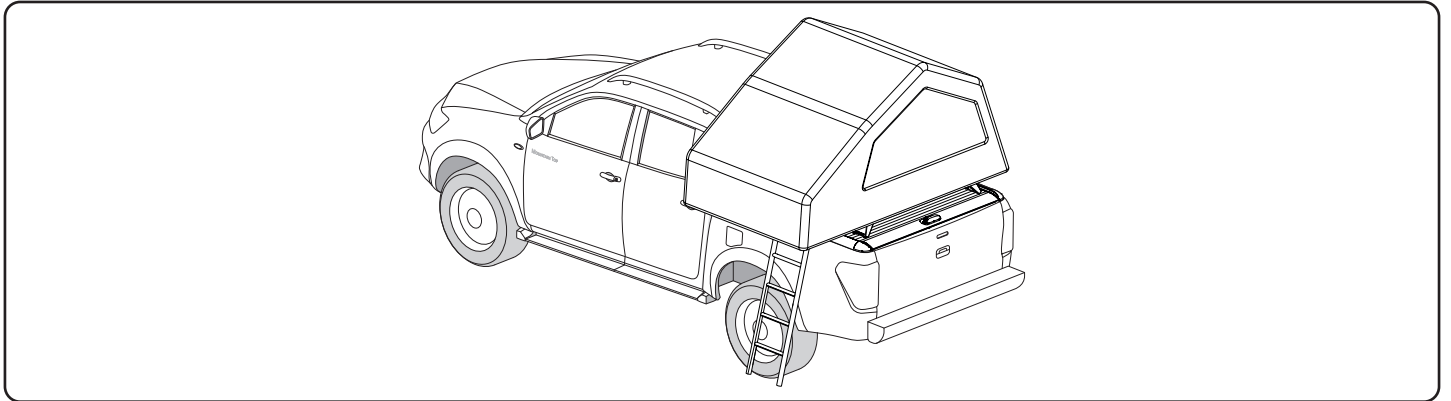
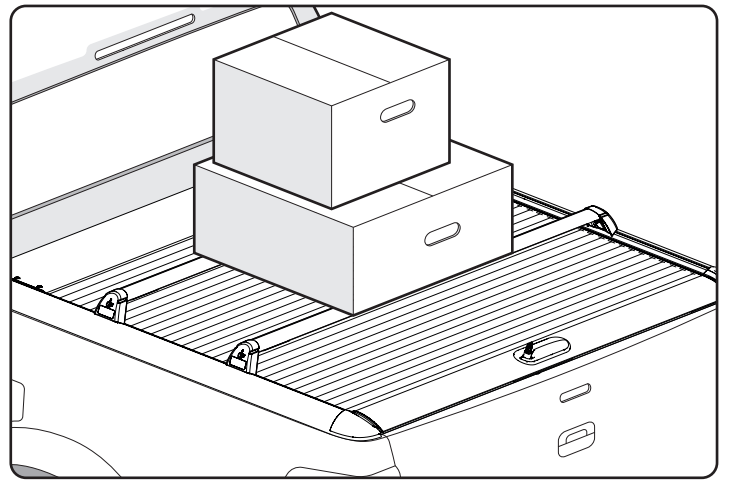
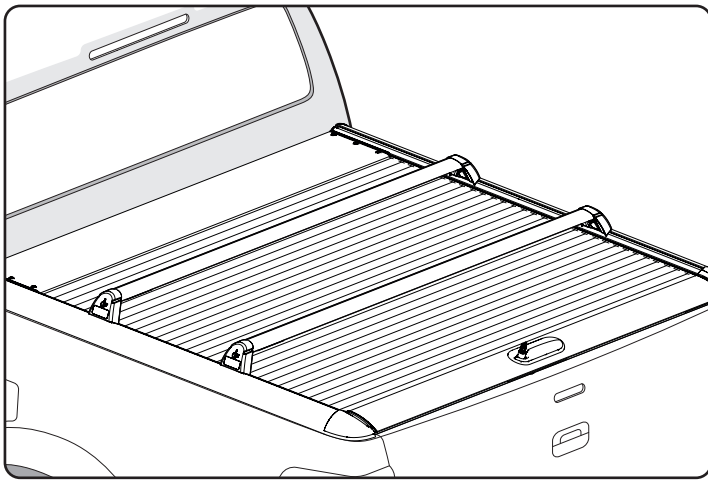

Fig. 2



1 Conditions of use

- This manual should be used in conjunction with the 'Owners Manual' for your Mountain Top Roll cover.
 - Refer to the Mountain Top Roll 'Owners Manual' & 'Instruction Manual' for information on correctly adjusting your cover and regular maintenance requirements.
- The Mountain Top Tub Bracing Kit is made of steel bracketry.
- The purpose of the Mountain Top Tub Bracing Kit is to increase the load carrying capacity of your Mountain Top Roll by bracing the cover to the vehicle tubs structural members.
- The roll cover is not designed for loading although it can support normal snow loads. No part of it can support any load from cargo or persons and the product might be damaged if somebody stands on it. (Fig. 1)
- The Mountain Top Tub Bracing Brackets should not be used as tie down points for cargo. (Fig. 2).
- Check all bolted connections of roll cover and bracing kit after a short drive following the initial installation.
 - Tighten and/or readjust as necessary and check again at regular intervals.



- The load carrying capacity of your Mountain Top Roll cover is increased when fitted with a Mountain Top Tub Bracing Kit.
- The Load Carrying Capacity is increased to 150kg with condition.
 - Contact Mountain Top for further information.
 - Refer to the vehicle owners manual for maximum load rating and always use the lower of the two figures.
 - The Load Carrying Capacity includes the weight of all ancillary products attached to roll cover, such as Sports Bars, Cargo Carriers, Tub Rack Mounts & Platform.
 - Load must be evenly distributed over the load bars/platform and should be mounted as low as possible.
- It is permissible to mount a Roof Top Tent to the roll cover using Mountain Top Tub Rack Mounts.
 - Where crossbars have suitable load rating.
 - It is permissible to drive your vehicle with a Roof Top Tent mounted above the roll cover as long as the total weight supported by the Tub Rack Mounts is less than 150kg.
 - While your vehicle is parked, the maximum permissible weight supported by the Tub Rack Mounts is 300kg. For example, this includes the weight of the Roof Top Tent, bedding, and occupants of the tent.



Customer Service 03 9791 9303 (08:00 - 16:00 CET)
Support info@mountaintop.com.au
Website www.mountaintop.com.au
Address Dandenong South, Victoria 3175, Australia

Part number (s)	Model / Year	Cab type (s)	Installation time	Weight
TB F090 B02	Ford Wildtrak / 2014 - 2019	All	1 hour (s)	4,4 Kg

GB Installation manual	S Monteringsanvisning	D Einbauanleitung
SF Asennusohje	E Instrucciones de montaje	CZ Návod k instalaci
F Notice de montage	H Szerelési utasítás	I Istruzioni de montaggio
PL Instrukcja montażu	P Instruções de instalação	GR Οδηγίες Εγκατάστασης
NL Installatie-instructies	RUS Инструкция по установке	DK Monteringsvejledning
TR Montaj Talimatı	N Monteringsveiledning	RO Instructiuni de instalare